

1	2		3		4	
XX ±0.1	XXX ±0.05	Items	Requirements		Items	Requirements
A	[G] Key parameter [B] Blind hole [T] Through-hole	Breach	Maximum 4 positions for ≤1×1×1mm. Maximum 2 positions for ≤2×2×1mm. Maximum 1 positions for ≤3×3×1mm.		Holes	≤φ0.5×0.5mm
					Gaps	No visible holes under ×10 magnifier.
					Dents	≤0.5×0.5×0.5mm
					Color	Minor color difference is allowed.

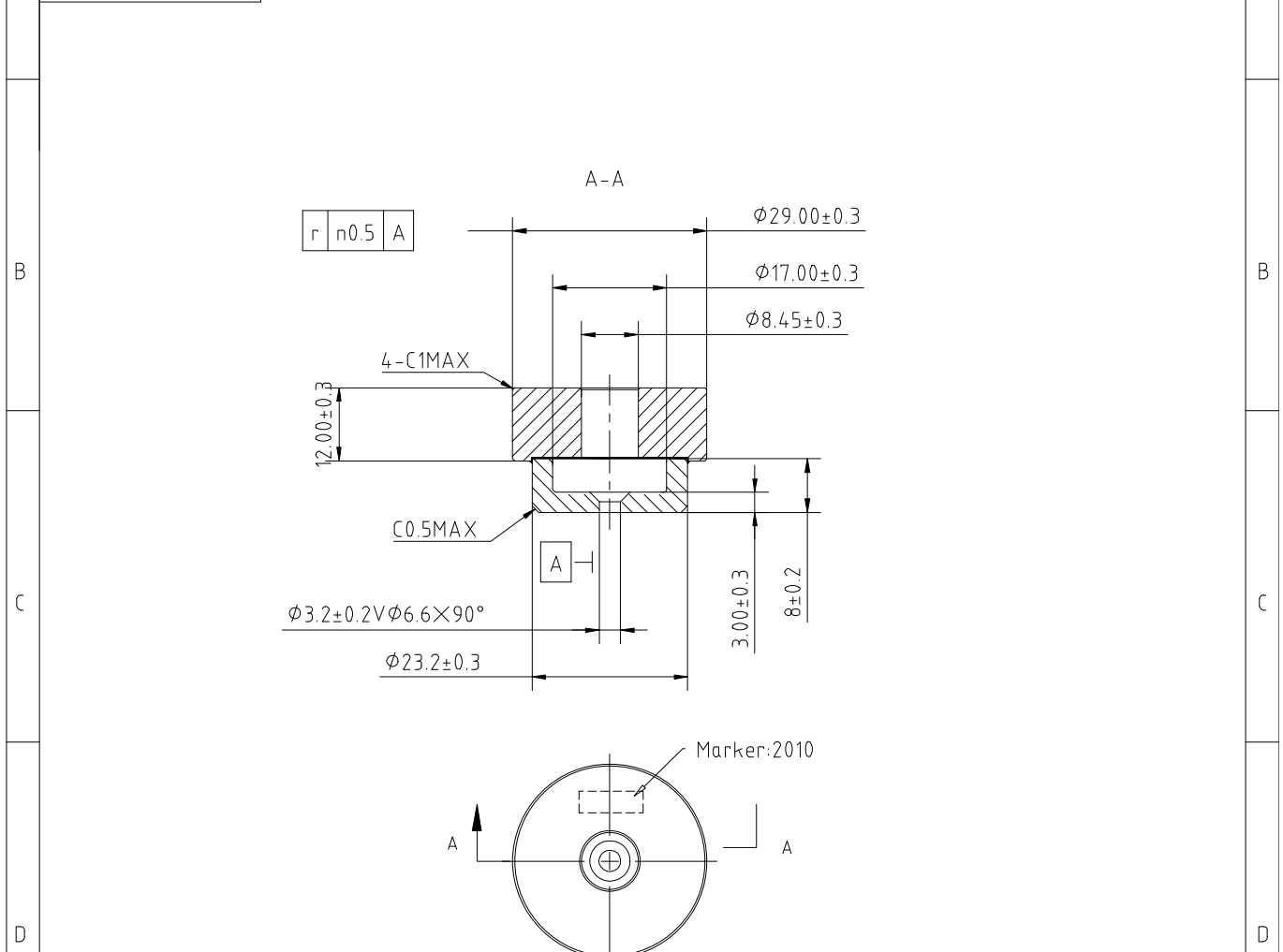

Technical Requirements:

1. Comply ROHS and REACH environmental requirements.
2. Electrical Parameters:
 - Unloaded Quality Value > 14000 (Without tuning plate).
 - Center Frequency: 2010MHz
 - Tunable Frequency: $f_0 \pm 4/-2$ MHz
 - Frequency Temperature Offset 0-300K for -40℃~+25℃ temperature range
 - Frequency Temperature Offset -300-0K for +25℃~+85℃ temperature range
3. The surface is smooth and even, without burrs or cracks.
4. The resonator shall be firmly adhered to the support block.
5. The test unit is circular with a size of φ 40 × 32 (diameter × height).
6. The support is made of ceramic, with a purity of 99% alumina.
7. Remove burrs, oil stains, and blunt sharp edges.

							CRN-2010-40-14000-01		
Mark	Ver.	ECN	Sign	Date	Dielectric Resonator		Version Mark	Weight	Scale
Design							S	1.2	1:1
Check					Dielectric Constant	4.0±1			
Process							Surface m ²		
Electrical					Material: K040		Page 1 of 2		
Standard									
Approve									

Reliability testing

- 1) Prior to the experiment, conduct the electrical performance test on the testing unit and ensure that the electrical performance meets the required standards. Subsequently, carry out the testing of the items specified in Table 1 in a sequential manner.
- 2) Upon completion of each test, inspect the appearance for any abnormalities such as cracks, peeling, adhesive detachment, or ceramic block detachment, and verify that the electrical performance meets the specified requirements.
- 3) Qualification criteria: The absence of any abnormalities during the testing process for all items, with no significant changes in electrical performance before and after the test, and compliance with the technical specifications.
- 4) Upon completion of all tests, provide detailed test reports based on the test results.

Table 1: Reliability Test Items and Requirements

NO.	Item	Requirements
1	Enclosure Strength	1) Tightening torque of fixing screws: ≥ 2.9 Nm; 2) The vertical tensile force between the ceramic and the bracket exceeds 100N, sustained for 1 minute. 3) The shear force between the ceramic and the bracket exceeds 100N, sustained for 1 minute.
2	Sine Vibration	Frequency: 10-55 Hz Amplitude: 0.75mm peak to peak value Time: 10-55 Hz / 5 minutes Number of cycles: 3 cycles per axis, for a total of 30 minutes Axial: 3-axis
3	Shock	Peak acceleration: 50 g Pulse duration: 11 ms Speed variation: Half sine wave, 3.4 m/s Axial: 3-axis Continuous impact times: 6 directions x 3 times
4	Low Temperature	Dielectric testing without metal casing Store at -55°C for 48 hours
5	High Temperature	Dielectric testing without metal casing Store at $+85^{\circ}\text{C}$ for 48 hours
6	Damp Heat Test	Dielectric testing without metal casing High temperature and humidity: $+55^{\circ}\text{C}$, 95%, 12 hours Low temperature and high humidity: $+25^{\circ}\text{C}$, 95%, 12 hours Test time: 2 cycles for a total of 48 hours
7	Temperature Shock	Dielectric testing without metal casing Low temperature: -55°C High temperature: $+85^{\circ}\text{C}$ Constant temperature duration: 3 hours Conversion duration: 1 minute Impact: 30 times



Mark	Ver.	ECN	Sign	Date	Dielectric Resonator	Version Mark		Weight	Scale
Design						S	1.2		
Check					Dielectric Constant				
Process									
Electrical					Material: K040				
Standard									
Approve						Page 2 of 2			