



The RF power splitter is widely used in the in-building DAS deployment, with wide frequency band, customized connector interface, high power handling, low PIM performance and high reliability for indoor coverage applications.

## General Specifications

Product Type	RF power splitter, power divider
Frequency Band	694-4200 MHz
Branches	3-way
Connector Interface	4.3-10 female

## Electrical Specifications

Frequency Band (MHz)	694-4200 MHz
Insertion Loss	≤0.1dB
Split Loss Nominal	4.8 dB
Split Loss Ripple	±0.4 dB
VSWR	≤1.25
Power Handling	500W
Intermodulation, 2×43dBm	≤-155dBc
Impedance	50 ohms

## Material Specifications

Cavity	Cavity Enclosure	Aluminum alloy
	Cavity Outer Surface Treatment	Black painting
	Cavity Inner Surface Treatment	Cu3Ag1
	Inner Conductor	Aluminum alloy
Connector	Inner Conductor Surface Treatment	Ag1
	Outer Conductor	Brass
	Outer Conductor Surface Treatment	Tri-metal CuSnZn3
	Inner Conductor	Brass
	Inner Conductor Surface Treatment	Ag1
	Insulator	PTFE/TPX
	Gasket	Silicon rubber

## Mechanical Specifications

Dimension	230×25×25 mm (Excluding connectors and brackets)
Weight	0.6 kg
Connectors Type	4.3-10 female
Mounting	Wall or rack
Packing	1pcs in box

## Environmental Specifications

Operating Temperature	-40 °C to +65 °C
Storage Temperature	-45 °C to +85 °C
Relative Humidity	5% - 95%
Application	Indoor

## Outline Drawing

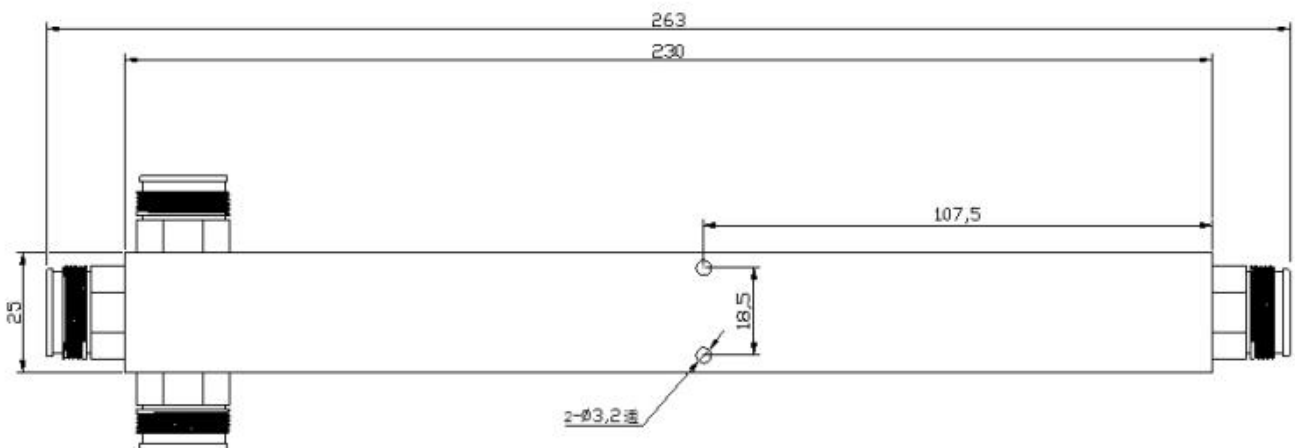

## Regulatory Compliances

ISO 9001:2015	Compliant
ROHS	Compliant
China RoHS	Compliant
UK RoHS	Compliant
REACH	Compliant
EU/CE	Compliant

In the effort to improve our products, we reserve the right to make changes judged to be necessary. While the information has been carefully compiled to the best of our knowledge, but nothing is intended as representation or warranty on our part and no statement herein shall be construed as recommendation to infringe existing patents. The information contained in this document is subject to change without notice.